



# 23" (584 mm) Diameter Continuous Liner Systems



## SYSTEM DESCRIPTION

This easy-to-use system has been proven effective in containing active pharmaceutical ingredients API's and other hazardous compounds to assure a safe and effective transfer of powders - an operational requirement that cannot be achieved with a standard drum liner.

The 23" (584 mm) diameter continuous liner system is designed to facilitate enable continuous offloading of powders into drums. This contained powder transfer system consists primarily of a pack ready to install on the canister. Standard systems are supplied in continuous sleeves.

## BENEFITS

- Contained processing to protect the operators
- GMP processing in a completely closed operation to protect the product
- Single person operations
- Pre-loaded liner material minimizes processing time
- Significant reduction in cleaning time, waste, and validation expenses

The system is available in the following sizes:

Pack Length	Number of Drums per Pack*
50'	10
100'	20
150'	30

\*assumes 5' of liner per drum to accommodate drum height and crimping. Actual usage will depend on the drum height



# 23" (584 mm) Diameter Continuous Liner Systems

The basic steps for operating this easy to use system are shown in these continuous liner process steps



Versatile hardware easily mounts to vessel discharge port

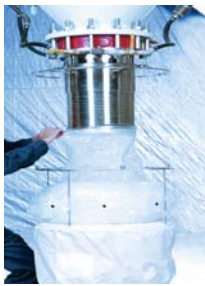

Continuous liner pack is installed



Sleeve is pulled into drum and filled



Unique Dover-Pac® crimping system is used to separate filled drum



Next sleeve is pulled into drum

## Materials

ArmorFlex® is ILC Dover's proprietary family of films.

These films pass incendivity testing and are designed and manufactured using FDA & EU compliant materials.

## Continuous Liner Components

The Continuous Liner Kit includes:

- Canister
- Cage
- Shroud
- Pack Protector
- 12" Band Clamp
- Sanitary Clamp and Gasket
- FlexLoc™ Clamp
- 23" Crimp Kit
- Turn Table
- Continuous Liner Pack

The canister will attach to the vessel using a transition adapter. The transition adapter has a nitrogen purge/vent to discharge into an inert atmosphere (if required).

## Continuous Bag-in/Bag-out System

The system can be supplied with an alpha/beta port interface to allow attachment to an isolator as depicted in the drawing. This allows the contained removal of product containers, samples, or waste from the isolator.

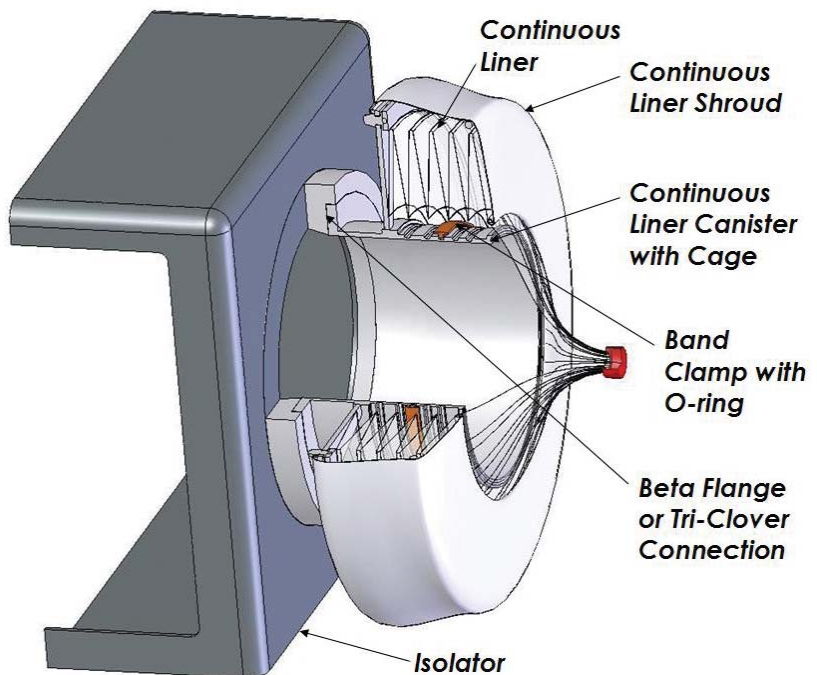

# 23" (584 mm) Diameter Continuous Liner Systems

## Crimp Separation Kit

The 23" crimp separation kit is used to separate the filled drum from the unused pack. The 23" Crimp Separation (start-up) Kit includes:

- 200 Crimps
- 1 CrimpLoc™ tool
- 1 Cutter
- 100 Cable Ties (7" Nylon)
- 1 User's Manual

Additional spare items can be ordered separately by their individual model/part numbers.

The crimps have been designed and tested to compress the standard 23" diameter liners made with ArmorFlex® film. Use on any other system will preclude the crimps from closing correctly, which could result in operator and product exposures.

The hand tool applies two crimps at once. The cutter is then used to cut between the two crimps, and the cap is slid onto the closed crimp body.

## FlexLoc™ Clamp

The FlexLoc clamp is used to secure the neck of the liner to the canister. Construction of the molded clamp is of FDA compliant elastomer with integrated stainless steel band clamp. The clamp has a molded ridge along one surface to help install it in the correct orientation.



FlexLoc Clamp

The FlexLoc functions to prevent powder from going between the inside of the liner and the outside of the canister to minimize cleaning operations. The clamp is designed to operate in the offloading and the charging operations.

## Containment Levels

While specific powders react differently due to their particle size, customer testing has shown that these systems are capable of providing containment levels to below 1 µg/m<sup>3</sup> in applications around the world.

ILC crimps have been designed and tested to compress standard diameter liners made with ArmorFlex® film



Load crimp into installation tool



Position crimp



Squeeze tool until crimps are engaged—then release tool



Cut and separate



Install crimp cap on crimp body

**ARMORFLEX, FLEXLOC, CRIMPLOC ARE TRADEMARKS OF ILC DOVER**

# 23" (584 mm) Diameter Continuous Liner Systems

## Continuous Liner Discharge Arrangement

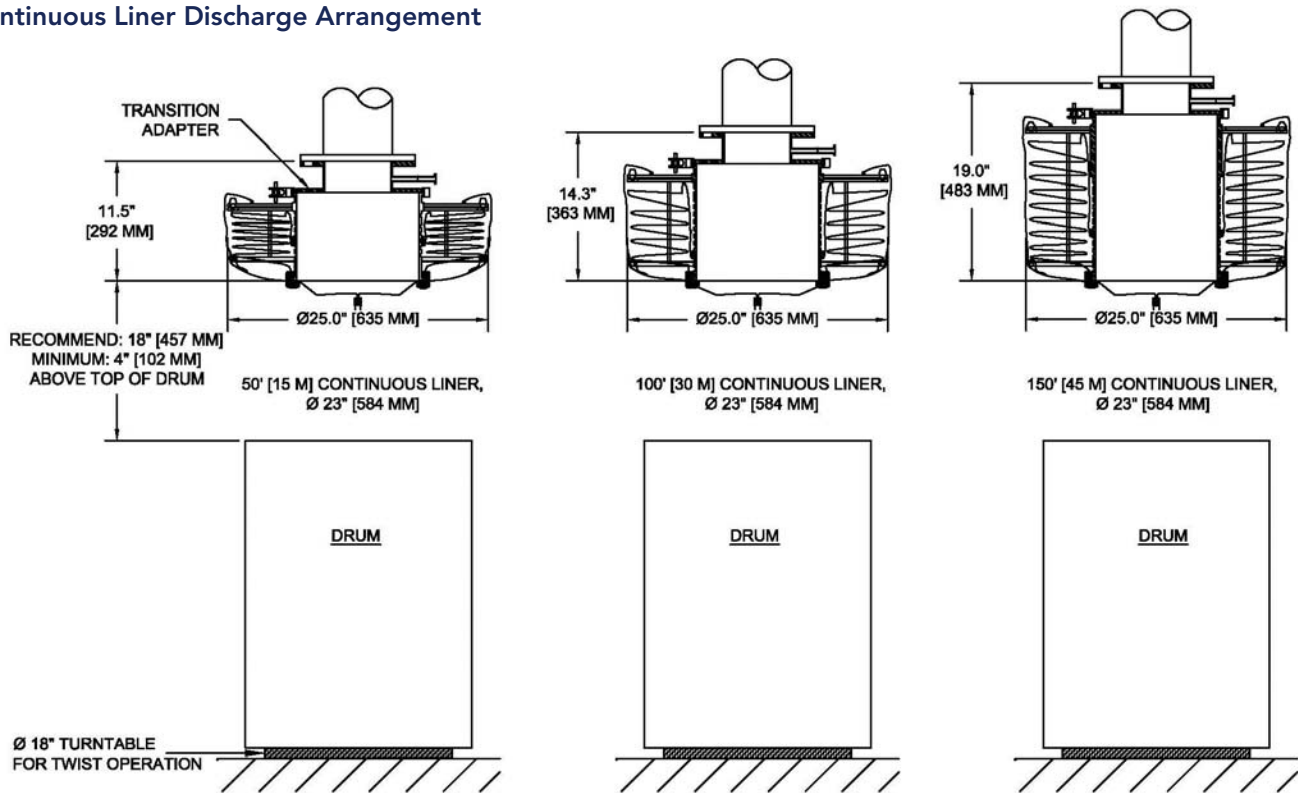

## Other System Components and Accessories

Other system components and accessories developed by ILC Dover to support contained pharmaceutical ingredient processing include:

- Wash In Place Enclosure
- Clean In Place System
- In Line Filter Kit

## Applications

- Product offloading from sifters, mills, blenders, centrifuges, dryers and other process equipment.
- Bag-in/Bag-out

Beyond Boundaries™.

Innovators at our core, we develop engineered solutions for our customers' complex problems. Recognized globally for our flexible containment solutions, ILC Dover serves customers in a diverse range of industries, including pharmaceutical and biopharmaceutical manufacturing, personal care, food and beverage, chemical, aerospace, healthcare and government agencies. At ILC Dover, quality is a culture, not a measurement. Our customers will tell you that we cater to their every need and that we're highly innovative, responsive, dedicated and competitive. We have been innovating since 1947. ILC Dover's visionary solutions improve efficiency, safeguard workers and product, and prevent disasters – proof that we are on the front line of business excellence.

Engineering evolution beyond boundaries.



One Moonwalker Road  
Frederica, DE 19946 USA  
+1.302.335.3911  
+1.800.631.9567  
customer\_service@ilcdover.com

[www.ilcdover.com](http://www.ilcdover.com)

